

CENTRALISED LUBRICATION SYSTEM

SINGLE SHOT TYPE



 **CENLUB**
CENLUB INDUSTRIES LTD.

INTRODUCTION

CENLUB Single Shot Centralised Lubrication System for MACHINE/MACHINE TOOLS is an efficient and safe method for a predetermined amount of oil to be delivered at various lubrication points of a Machine/Equipment from a centralised source. It is a TOTAL LOSS SYSTEM and does not require any return line for collection of used oil.

ADVANTAGES :

1. Appropriate Oil Consumption
2. Variable Oil Dosages
3. Enhanced Machine Life
4. Elimination of Human Error
5. Less Wear & Tear
6. Lubrication during running of M/c
7. Reduced Spares/Inventory Costs
8. Overall Increased Profitability

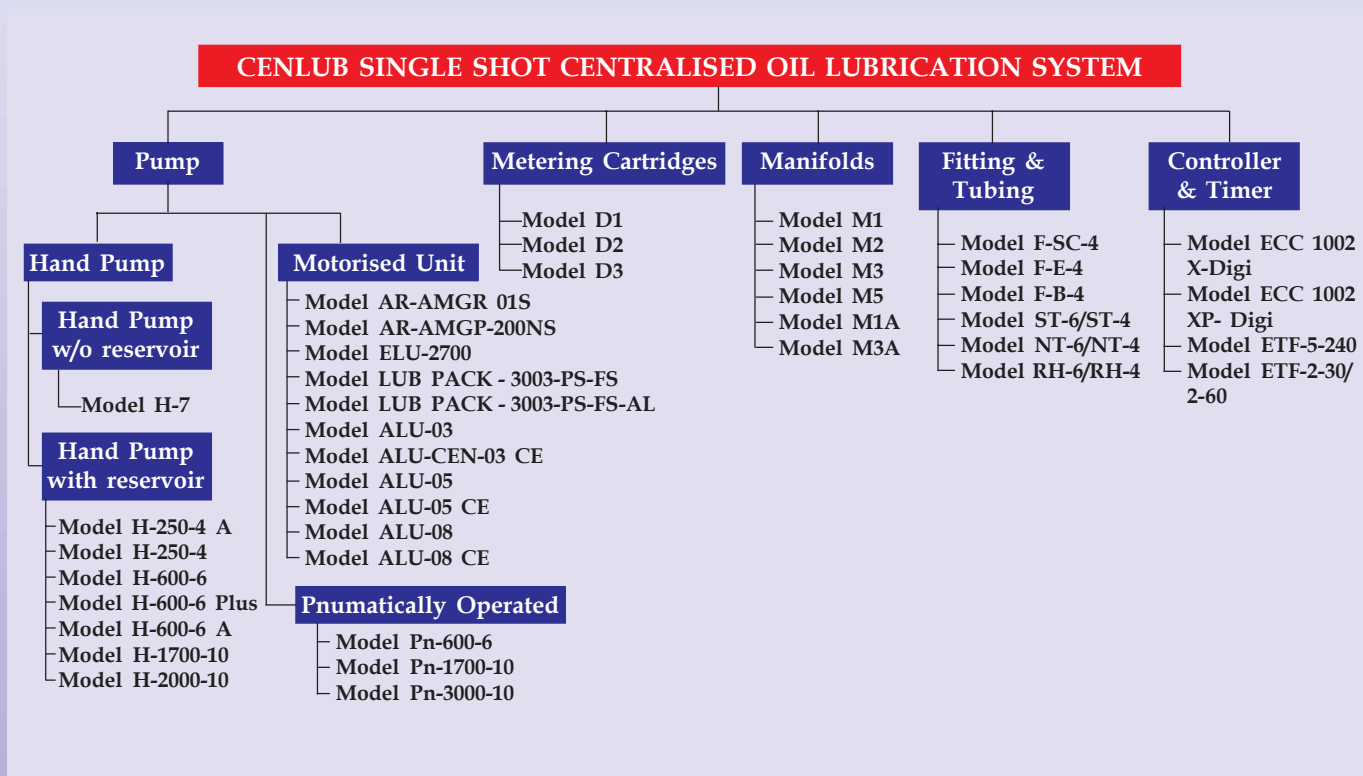

As illustrated above, basically the system comprises of five elements.

- **PUMP** - A central source of oil pressure in lubrication line
- **METERING CARTRIDGES** - A mini-cylinder with check valve, where stroke of piston determines amount of dispensed oil. Designed for intermittent operation by pressurising & de-pressurising of lub line.
- **MANIFOLDS** - Steel blocks for mounting metering cartridges and for main line distribution.
- **TUBINGS & FITTINGS** - Available for transmitting oil in main and secondary line.
- **TIMERS & CONTROLLERS** - High performance solid state instrument for automatic control & monitoring of motorised centralised lubrication units.

MAJOR APPLICATION AREAS :

- Machine Tools
- Injection/Blow Moulding M/cs
- Packaging Equipments
- Food Processing Equipments
- Metal Forming M/cs
- Shearing & Press Brakes
- Sheet Metal Working M/cs
- Textile M/cs
- Printing M/cs
- Presses & Hammers
- Pharmaceuticals M/cs
- Calendering M/cs
- Rubber Processing M/cs
- Die Casting M/cs
- etc. etc.

SINGLE SHOT OIL SYSTEM



THE SYSTEM (SINGLE SHOT TYPE)

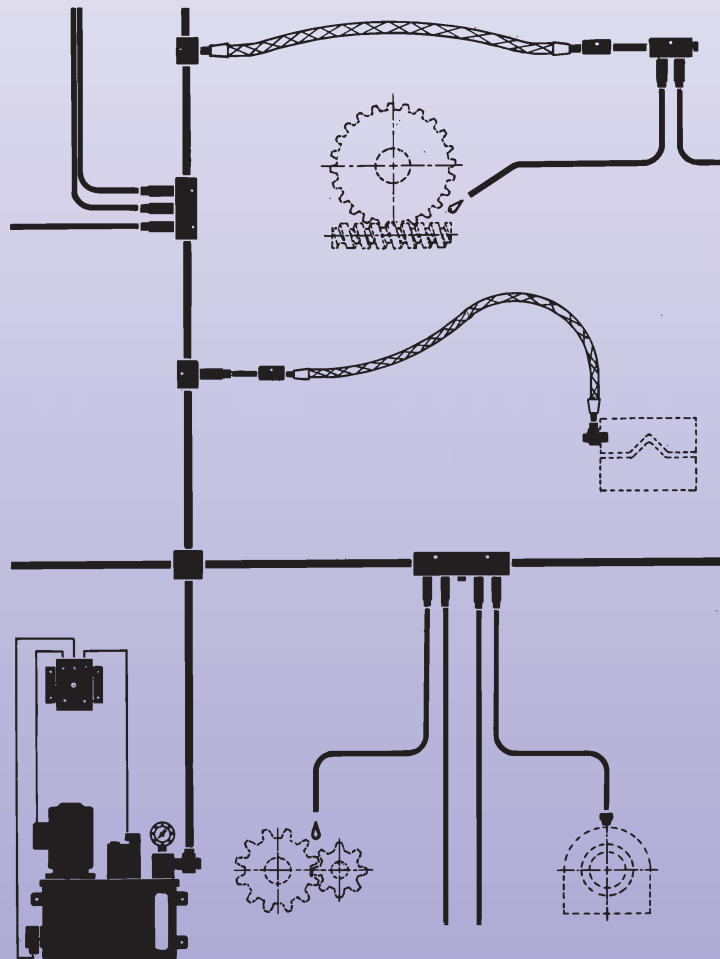

SINGLE SHOT OIL SYSTEM



CHAPTER-1

PUMP

Hand Pump without reservoir

MODEL H-7

- This is a simple pump meant for delivering oil in lubrication line.
- It is ideally suited for general purpose machine, where pump can be inserted into oil reservoir of the machine or can be mounted separately in machine casing below the reservoir.
- The pump is actuated by hand pull and release of handle as per lubrication requirement.
- It is advisable to attach a suction strainer before the inlet of the pump to avoid damage to pump's piston.
- Relief valve, if required, is available as optional accessory.

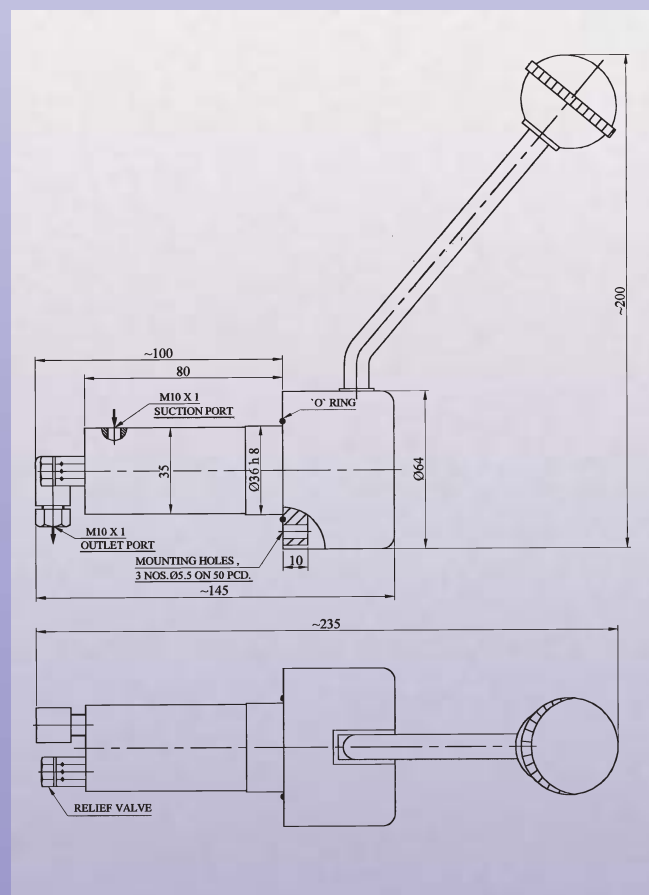
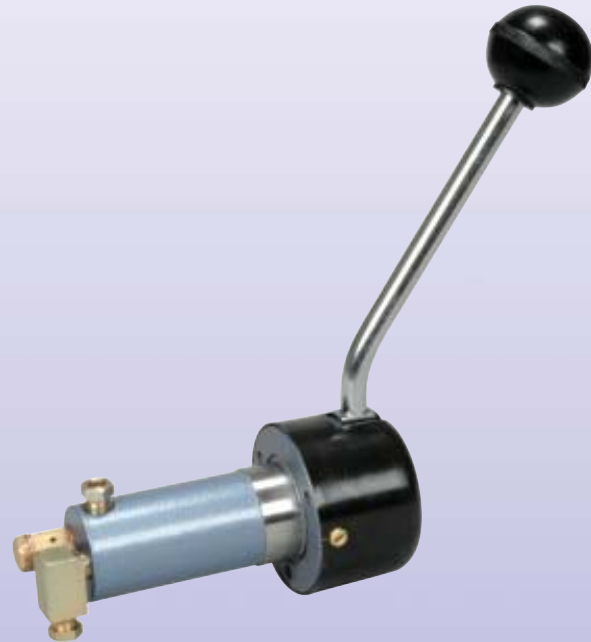

Pressure : 15 kg/cm²

Discharge : 7 cc per stroke

Suitable for direct connection of 6mm O.D. Tube.

Suitable for oil with viscosity 32 - 320 cSt/40° C.

Best suited for small general purpose machines.

CHAPTER-2

PUMP

Hand Pump with reservoir

MODEL H-250-4 A

- This pump has its own reservoir made of acrylic.
- It is piston type, where piston is actuated by a cam, integral with the handle of the pump.
- On operating the handle, pump discharges oil.
- As soon as the pulling force on the handle is released, piston returns back by spring force and the pressure in the lubrication line is reduced to 1kg/sq.cm.
- There is an in-built check valve and pressure reducing system incorporated in the pump.
- Pump is equipped with relief valve, which safeguards it from overloading.
- The acrylic body of pump facilitates the cross-checking of the level of oil in the pump and to refill the reservoir from the top opening, once the oil level is nearing the minimum.
- Pump is equipped with a suction strainer at the inlet and a drain plug at the bottom of the reservoir.
- Suitable holes are provided for vertical mounting of the pump.
- Pump outlet is suitable for 6 mm dia tube.

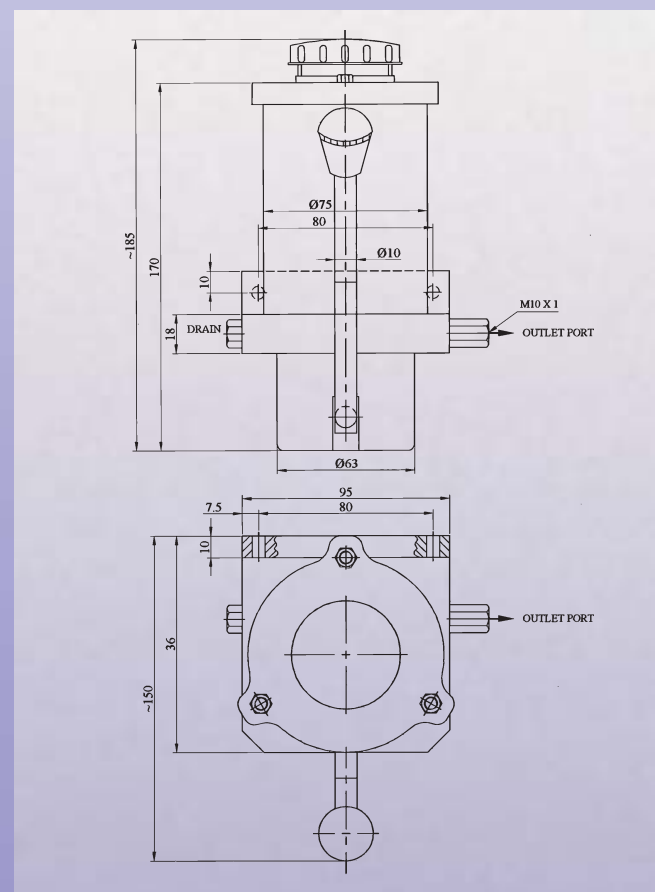

Pressure	: 15 kg/cm ²
Discharge	: 4cc per stroke
Reservoir capacity	: 250 cc
Material of reservoir	: Acrylic
Suitable for oil with viscosity 32 - 320 cSt/40° C.	
Best suited for small machines.	

CHAPTER-3

PUMP

Hand Pump with reservoir

MODEL H-250-4

- This pump has its own reservoir.
- It is piston type, where piston is actuated by a cam, integral with the handle of the pump.
- On operating the handle, pump discharges oil.
- As soon as the pulling force on the handle is released, piston returns back by spring force and the pressure in the lubrication line is reduced to 1kg/sq.cm.
- There is an in-built check valve and pressure reducing system incorporated in the pump.
- Pump is equipped with relief valve, which safeguards it from overloading.
- Pump is fitted with an oil window to cross-check the level of oil in the pump and to refill the reservoir from the top opening, once the oil level is nearing the minimum.
- Pump is equipped with a suction strainer at the inlet and a drain plug at the bottom of the reservoir.
- Suitable holes are provided for vertical mounting of the pump.
- Pump outlet is suitable for 6 mm dia tube.

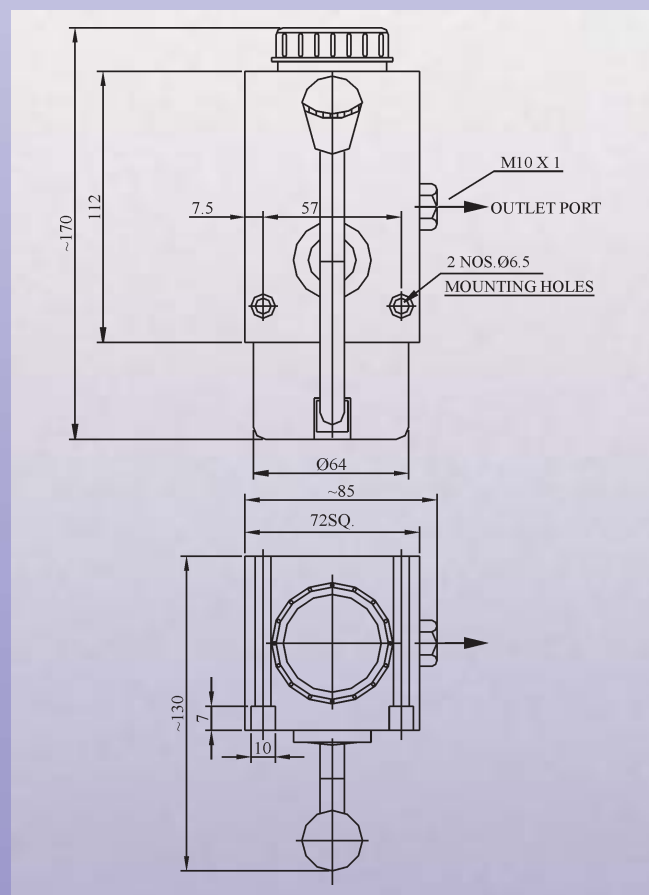

Pressure	: 12 kg/cm ²
Discharge	: 4cc per stroke
Reservoir capacity	: 250 cc
Material of reservoir	: Aluminium casting
Suitable for oil with viscosity 32 - 320 cSt/40° C.	
Best suited for small size machines.	

CHAPTER-4

PUMP

Hand Pump with reservoir

MODEL H-600-6

- This pump has its own reservoir.
- It is piston type, where piston is actuated by a cam, integral with the handle of the pump.
- On operating the handle, pump discharges oil.
- As soon as the pulling force on the handle is released, piston returns back by spring force and the pressure in the lubrication line is reduced to 1kg/sq.cm.
- There is an in-built check valve and pressure reducing system incorporated in the pump.
- Pump is equipped with relief valve, which safeguards it from overloading.
- Pump is fitted with an oil window to cross-check the level of oil in the pump and to refill the reservoir from the top opening, once the oil level is nearing the minimum.
- Pump is equipped with a suction strainer at the inlet and a drain plug at the bottom of the reservoir.
- Suitable holes are provided for vertical mounting of the pump.
- Pump outlet is suitable for 6 mm dia tube.

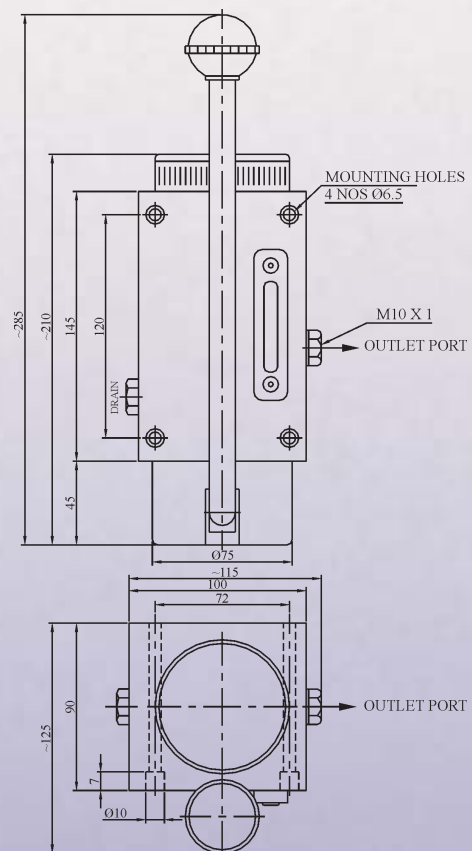

Pressure	:	18 kg/cm ²
Discharge	:	6cc per stroke
Reservoir capacity	:	600 cc
Material of reservoir	:	Aluminium casting
Suitable for oil with viscosity 32 - 460 cSt/40° C.		
Best suited for medium size machines.		

SINGLE SHOT OIL SYSTEM



CHAPTER-5

PUMP

Hand Pump with reservoir

MODEL H-600-6 PLUS

- This pump has its own reservoir made of aluminium die casting.
- It is piston type, where piston is actuated by a cam, integral with the handle of the pump.
- On operating the handle, pump discharges oil.
- As soon as the pulling force on the handle is released, piston returns back by spring force and the pressure in the lubrication line is reduced to zero kg/sq.cm.
- There is an in-built check valve and pressure reducing system incorporated in the pump.
- Pump is equipped with relief valve, which safeguards it from overloading.
- Pump is fitted with an oil window to cross-check the level of oil in the pump and to refill the reservoir from the top opening, once the oil level is nearing the minimum.
- Pump is equipped with a suction strainer at the inlet and a drain plug at the bottom of the reservoir.
- Suitable holes are provided for vertical mounting of the pump, projected outside the back wall of the pump.
- Pump outlet is suitable for 6 mm dia tube, which must go upward from pump outlet.

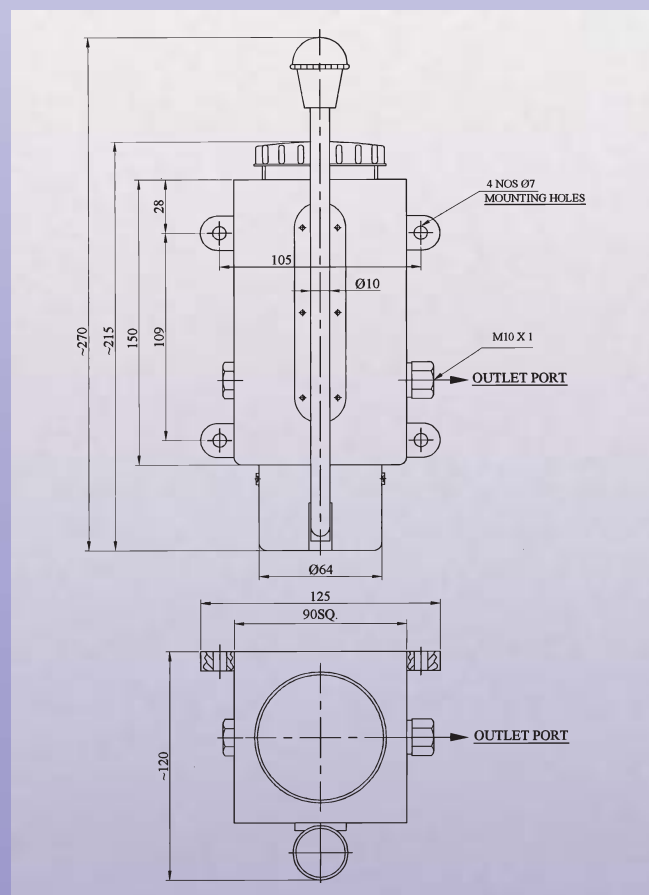

Pressure	:	18 kg/cm ²
Discharge	:	6cc per stroke
Reservoir capacity	:	600 cc
Material of reservoir	:	Aluminium die casting
Suitable for oil with viscosity 32 - 460 cSt/40° C.		
Best suited for medium size machines.		

CHAPTER-6

PUMP

Hand Pump with reservoir

MODEL H-600-6 A

- This pump has its own reservoir made of acrylic.
- It is piston type, where piston is actuated by a cam, integral with the handle of the pump.
- On operating the handle, pump discharges oil.
- As soon as the pulling force on the handle is released, piston returns back by spring force and the pressure in the lubrication line is reduced to 1kg/sq.cm.
- There is an in-built check valve and pressure reducing system incorporated in the pump.
- Pump is equipped with relief valve, which safeguards it from overloading.
- The acrylic body of pump facilitates the cross-checking of the level of oil in the pump and to refill the reservoir from the top opening, once the oil level is nearing the minimum.
- Pump is equipped with a suction strainer at the inlet and a drain plug at the bottom of the reservoir.
- Suitable holes are provided for vertical mounting of the pump.
- Pump outlet is suitable for 6 mm dia tube.

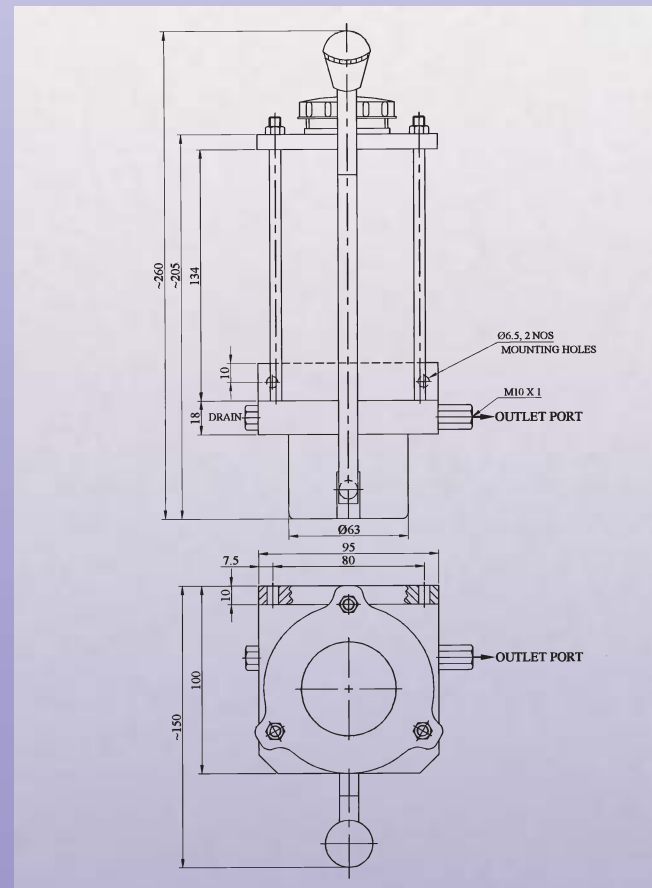

Pressure	:	15 kg/cm ²
Discharge	:	6 cc per stroke
Reservoir capacity	:	600 cc
Material of reservoir	:	Acrylic
Suitable for oil with viscosity 32 - 320 cSt/40° C.		
Best suited for medium size machines.		

SINGLE SHOT OIL SYSTEM



CHAPTER-7

PUMP

Hand Pump with reservoir

MODEL H-1700-10

- This pump has its own reservoir.
- It is piston type, where piston is actuated by a cam, integral with the handle of the pump.
- On operating the handle, pump discharges oil.
- As soon as the pulling force on the handle is released, piston returns back by spring force and the pressure in the lubrication line is reduced to 1kg/sq.cm.
- There is an in-built check valve and pressure reducing system incorporated in the pump.
- Pump is equipped with relief valve, which safeguards it from overloading.
- Pump is fitted with an oil window to cross-check the level of oil in the pump and to refill the reservoir from the top opening, once the oil level is nearing the minimum.
- Pump is equipped with a suction strainer at the inlet and a drain plug at the bottom of the reservoir.
- Suitable mounting holes are provided for vertical mounting of the pump.
- Pump outlet is suitable for 6 mm dia tube.

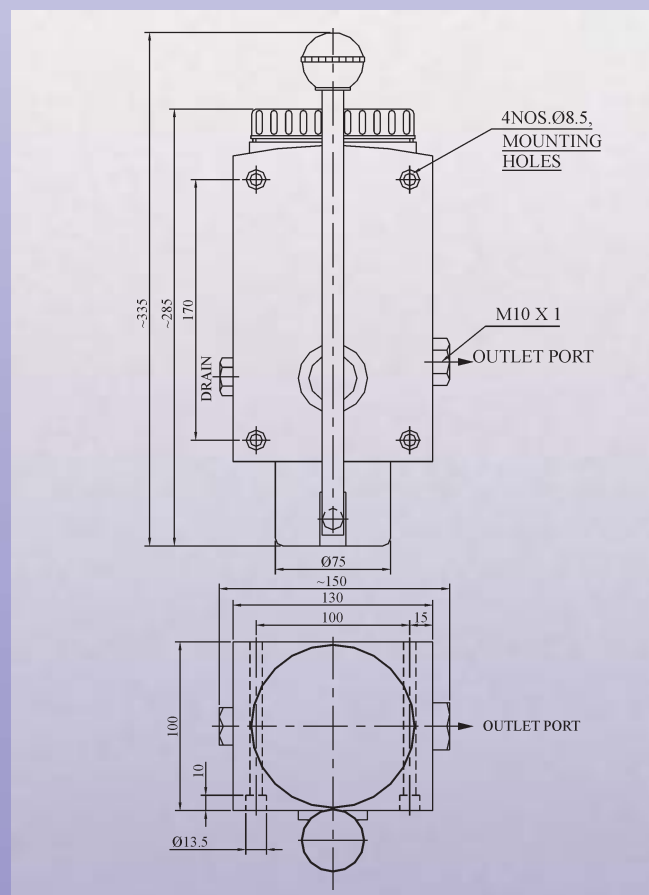

Pressure : 20 kg/cm²
Discharge : 10 cc per stroke
Reservoir capacity : 1700 cc
Material of reservoir : Aluminium casting
Suitable for oil with viscosity 32 - 680 cSt/40° C.
Best suited for big size machines.

CHAPTER-8

PUMP

Hand Pump with reservoir

MODEL H-2000-10

- This pump has its own reservoir.
- It is piston type, where piston is actuated by a cam, integral with the handle of the pump.
- On operating the handle, pump discharges oil.
- As soon as the pulling force on the handle is released, piston returns back by spring force.
- Pump is also equipped with relief valve, which safeguards it from overloading.
- All contact parts of the pump are made of S.S. material, while the rubber parts are of viton.
- Suitable holes are provided for vertical mounting of the pump.
- Pump outlet is 1/2" NPT (F).
- The pump is suitable for water operation as well as other chemicals.
- At the outlet, there is a non return valve attached.

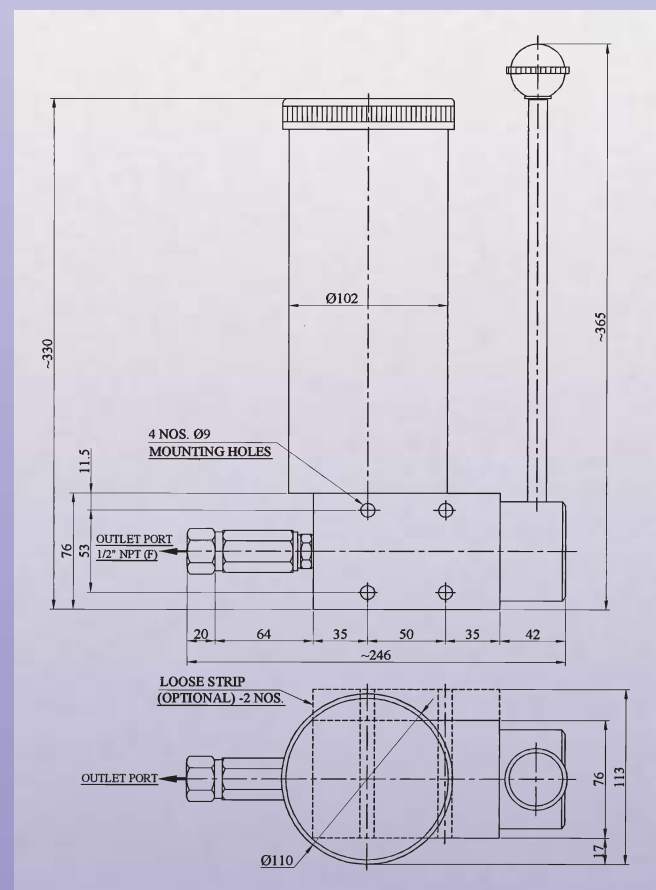

Pressure	:	50 kg/cm ²
Discharge	:	10 cc per stroke
Reservoir capacity	:	2000 cc
Material of reservoir and other contact parts	:	Stainless Steel
Rubber parts	:	Viton
Not suitable for metering cartridge operation.		
Suitable for water and other chemicals.		
Best suited for mechanical seal testing applications.		

SINGLE SHOT OIL SYSTEM



CHAPTER-9

PUMP

Mini Motorised Unit

MODEL AR-AMGR 01S

- This is a simple pump meant for delivering oil in lubrication line.
- It is ideally suited for general purpose machine, where pump can be inserted into oil reservoir of the machine or can be mounted separately in machine casing below the reservoir.
- The pump is actuated by hand pull and release of handle for as many times as per lubrication requirement.
- It is advisable to attach a suction strainer before the inlet of the pump to avoid damage to pump's piston. This strainer is supplied as optional accessory.
- Relief valve, if required, is available as optional accessory.



Discharge of pump : 200 cc/min.
Reservoir capacity : 1.0 ltr (in Polycarbonate).
Motor : 40 W, 1500 rpm, Single Phase, 220 V.
Relief valve : Pre-set at 15 kg/sq.cm.
Pressure switch : 220 V, 5 Amp. Pre-set at 12 kg/cm., 1No.
Digital Timer (optional) : ON time fixed = 5 secs; OFF time adjustable upto 999 mts.
Float switch : 24 V (No Contact)
Suitable oil viscosity : Between 32 to 220 cSt/40° C.
Best suited for small general/CNC machines.

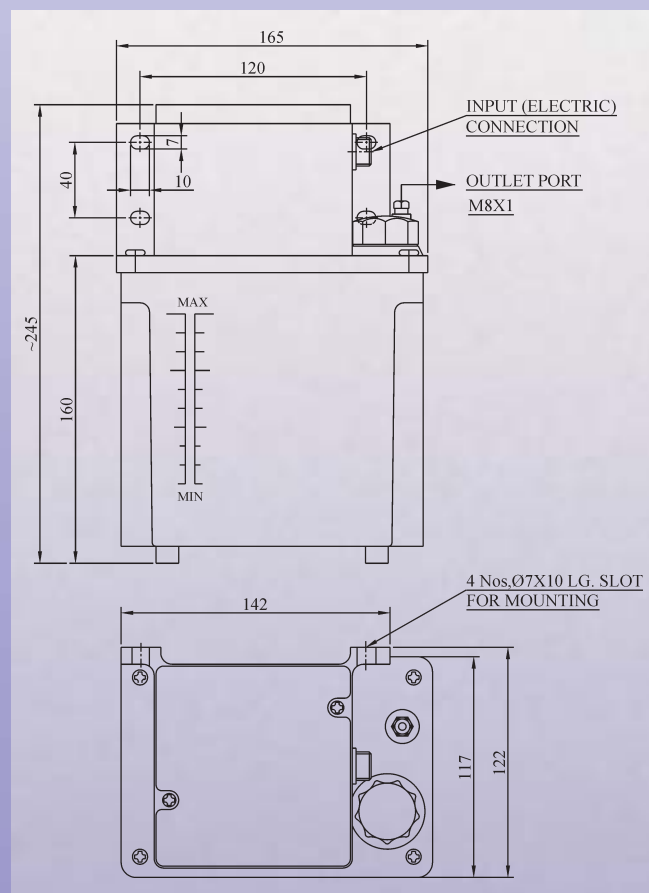

CHAPTER-10

PUMP

Motorised Unit

MODEL AR-AMGP-200NS

- This is a mini hydraulic power pack fitted with a motor and rotary positive displacement pump.
- The unit is designed for intermittent run only and is best suited for Single Shot Lubrication.
- Unit is fitted with a suitable pressure switch, float switch and a transparent reservoir (for visually checking the oil level).
- During ON cycle, the electrically driven pump discharges the oil with high pressure, adjustable between 10-12 bars, with the help of an in-built relief valve, which is also safeguarding the system from over-loading and the pressure can be read on the Pressure Gauge fitted on the unit.
- During OFF cycle the pressure in the lubrication line is reduced to 1 kg/sq.cm. and so on.
- The system is also provided with a Bleed Valve near the outlet port to automatically bleed air if entrained in system.
- For vertical mounting of the unit, four holes are provided at the back of the system. There is an in-built check valve and pressure reducing system incorporated in the pump. Unit is supplied with an adaptor (outlet port) of M10x1 tapping, fitted with a locking screw and a cone (ferrule), suitable for 6mm OD tube.

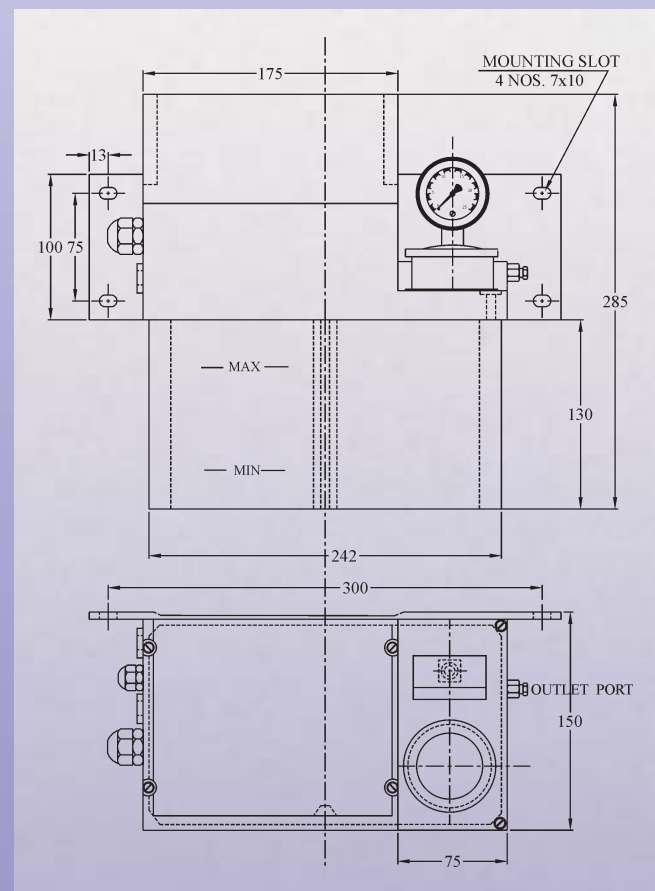

Discharge of pump	: 250 cc/min.
Reservoir capacity	: 3.0 ltrs. (in Polycarbonate).
Motor	: 40W, Single Phase, 110/220V.
Relief valve	: Pre-set at 20 kg/sq.cm.
Pressure switch	: Built in
Float switch	: Built in
Suitable oil viscosity	: Between 32 to 460 cSt/40°C.
Best suited for medium size CNC machines.	

SINGLE SHOT OIL SYSTEM



CHAPTER-11

PUMP

Motorised Unit

MODEL ELU-2700

- This is mini hydraulic power pack fitted with a motor and rotary positive displacement pump.
- The unit is designed for intermittent run only and is best suited for Single Shot Lubrication.
- Unit is fitted with a suitable pressure switch, float switch and a transparent reservoir (for visually checking the oil level).
- During ON cycle, the electrically driven pump discharges the oil with high pressure, adjustable between 15-20 bars, with the help of an in-built relief valve, which is also safeguarding the system from over-loading.
- During OFF cycle the pressure in the lubrication line is reduced to 1 kg/sq.cm.
- The system is provided with a bleed valve near the outlet port to automatically bleed air if entrained in system.
- For vertical mounting of the unit, two holes are provided at the back of the system.
- There is an in-built check valve and pressure reducing system incorporated in the pump.
- Outlet port is suitable for 6mm OD tube.



Discharge of pump	: 0.70 LPM.
Reservoir capacity	: 2.7 ltrs (in translucent PP material).
Motor	: 0.075KW, 4 pole, 1500 rpm, 3 phase, 415 V.
Relief valve	: Pre-set at 15-20kg/sq.cm.
Pressure switch	: 42 V (Max), 0.2 A (Max), Pre-set at 12 kg/sq. cm., 1NO+1NC contact.
Float switch	: Reed type vertical 42 V (Max.), 0.2 A (Max.), with 1 NC contact (Oil Filled)
Electronic controller	: Optional
Suitable oil viscosity	: Between 32 to 680 cSt/40°C.
Best suited for	medium size CNC machines.

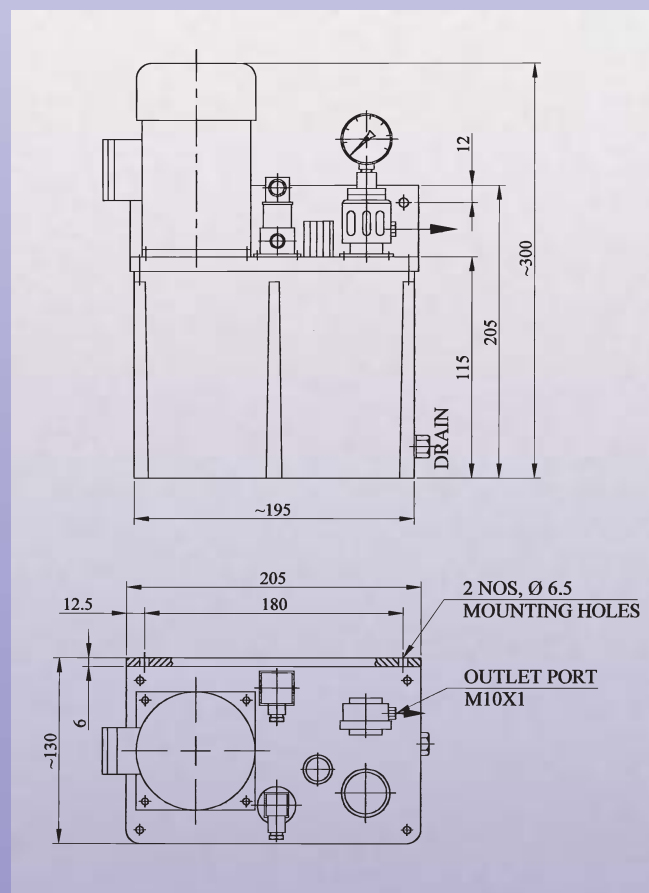

SINGLE SHOT OIL SYSTEM



CHAPTER-12

PUMP

Motorised Unit

MODEL LUB PACK - 3003-PS-FS

- This is a mini hydraulic power pack fitted with a motor and rotary positive displacement pump.
- The unit is designed for intermittent run only and is best suited for Single Shot Lubrication.
- Unit is fitted with a suitable pressure switch, float switch and oil window for checking oil level.
- During ON cycle, the electrically driven pump discharges the oil with high pressure, adjustable between 25-28 bars, with the help of an in-built relief valve for safeguarding the system from over-loading.
- During OFF cycle the pressure in the lubrication line is reduced to 1 kg/sq.cm.
- The system is also provided with a bleed valve near the outlet port to automatically bleed air if entrained in system.
- For vertical mounting of the unit, 2 holes are provided at the back of the system.
- There is an in-built check valve and pressure reducing system incorporated in the pump.
- Outlet port is suitable for 6mm OD tube.

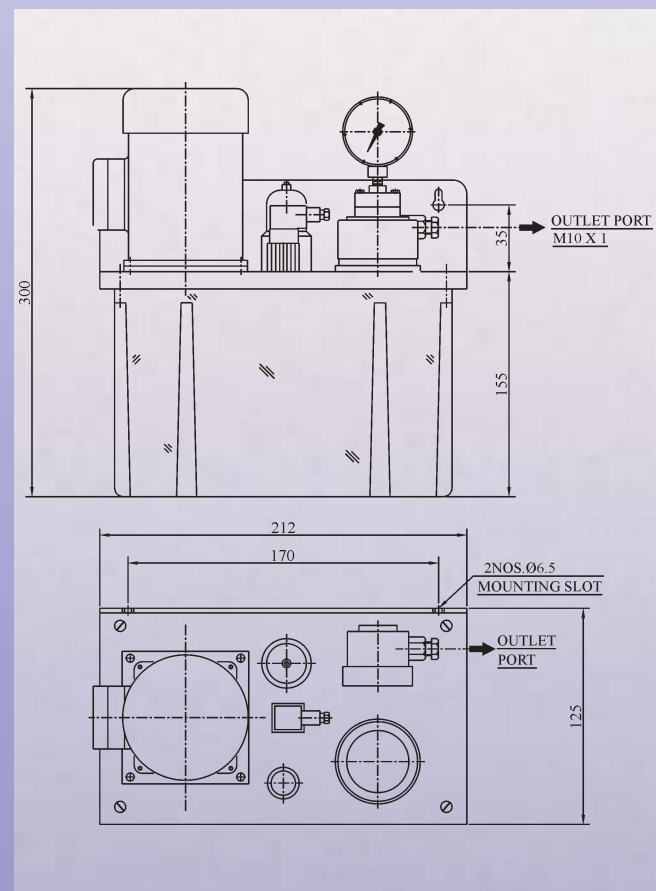

Discharge of pump	: 350 cc / minute
Reservoir capacity	: 3 ltrs. (in Polycarbonate).
Motor	: 0.09KW, 1500 rpm, 3 phase, 415 V.
Relief valve	: Pre-set at 20 kg/sq.cm.
Pressure switch (CE)	: 42 V (Max.), 0.2 Amp. (Max.), Pre-set at 12 kg/sq. cm., 1 NO + 1NC contact.
Float switch (CE)	: 42 V (Max.), 0.1 Amp. (Max.), (Vertical reed type) with, 1 NC contact (Oil filled).
Electronic controller	: Optional
Suitable oil viscosity	: Between 32 to 680 cSt/40° C
Best suited for sophisticated CNC machines.	

SINGLE SHOT OIL SYSTEM



CHAPTER-13

PUMP

Motorised Unit

MODEL LUB PACK - 3003-PS-FS-AL

- This is a mini hydraulic power pack fitted with a motor and rotary positive displacement pump.
- The unit is designed for intermittent run only and is best suited for Single Shot Lubrication.
- Unit is fitted with a suitable pressure switch, float switch and oil window for checking oil level.
- During ON cycle, the electrically driven pump discharges the oil with high pressure, adjustable at 28 bars, with the help of an in-built relief valve for safeguarding the system from over-loading.
- During OFF cycle the pressure in the lubrication line is reduced to 1 kg/sq.cm.
- The system is also provided with a bleed valve near the outlet port to automatically bleed air if entrained in system.
- For vertical mounting of the unit, 2 holes are provided at the back of the system.
- There is an in-built check valve and pressure reducing system incorporated in the pump.
- Outlet port is suitable for 6mm OD tube.

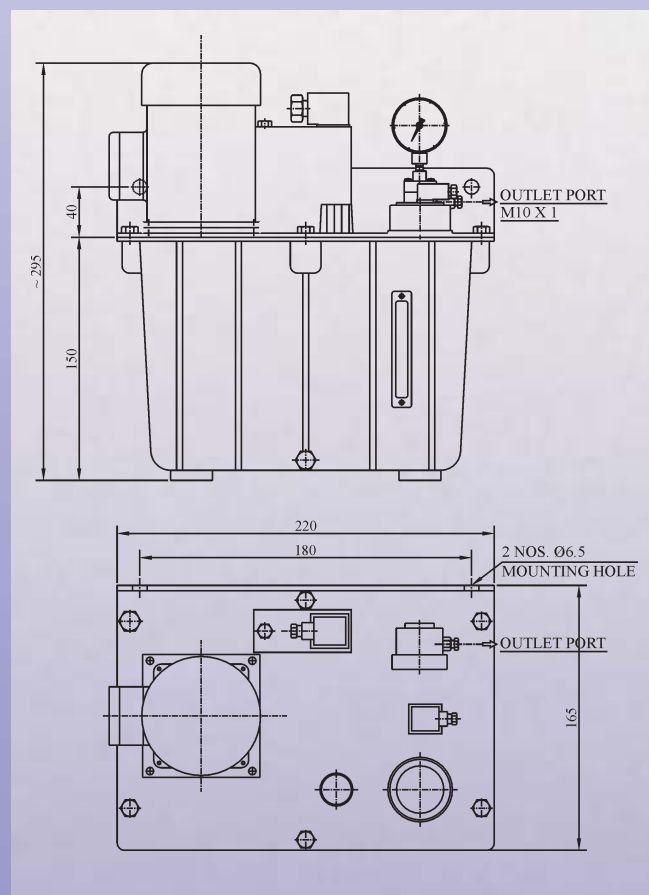

Discharge of pump	: 350 cc / minute
Reservoir capacity	: 3 ltrs. (in die cast aluminium).
Motor	: 0.09KW, 1500 rpm, 3 phase, 415 V.
Relief valve	: Pre-set at 25 kg/sq.cm.
Pressure switch	: 220 V (Max.), 0.1 Amp. (Max.), Pre-set at 20 kg/sq. cm., 1 NO + 1NC contact.
Float switch (CE)	: 42 V (Max.), 0.2 Amp. (Max.), with 1 NC contact (Oil filled).
Electronic controller	: Optional
Suitable oil viscosity	: Between 32 to 680 cSt/40° C
Best suited for sophisticated CNC machines.	

SINGLE SHOT OIL SYSTEM



CHAPTER-14

PUMP

Motorised Unit

MODEL ALU-03

- This is a mini hydraulic power pack fitted with a motor and rotary positive displacement pump.
- The unit is designed for intermittent run only and is best suited for Single Shot Lubrication.
- Unit is fitted with a suitable pressure switch, float switch and oil window for checking oil level.
- During ON cycle, the electrically driven pump discharges the oil with high pressure, adjustable between 15-18 bars, with the help of an in-built relief valve, for safeguarding the system from over-loading.
- During OFF cycle the pressure in the lubrication line is reduced to 1 kg/sq.cm.
- The system is also provided with a bleed valve near the outlet port to automatically bleed air if entrained in system.
- For vertical mounting of the unit, four holes are provided at the back of the system.
- There is an in-built check valve and pressure reducing system incorporated in the pump.
- Outlet port is suitable for 6mm OD tube.



Discharge of pump : 1 LPM.
Reservoir capacity : 3 ltrs. (in Mild Steel).
Motor : 0.09KW, 1500 rpm,
3 phase, 415 V.
Relief valve : Pre-set at 15-18 kg/sq.cm.
Pressure switch : 42 V (Max), 0.2 A (Max),
Pre-set at 12 kg/sq. cm.,
1NO+1NC contact.
Float switch : 220 V (Max), 0.2 A (Max)
NC contact (Oil filled)
Electronic controller : Optional
Suitable oil viscosity : Between 32 to 680 cSt/40°C.
Best suited for medium size machine.

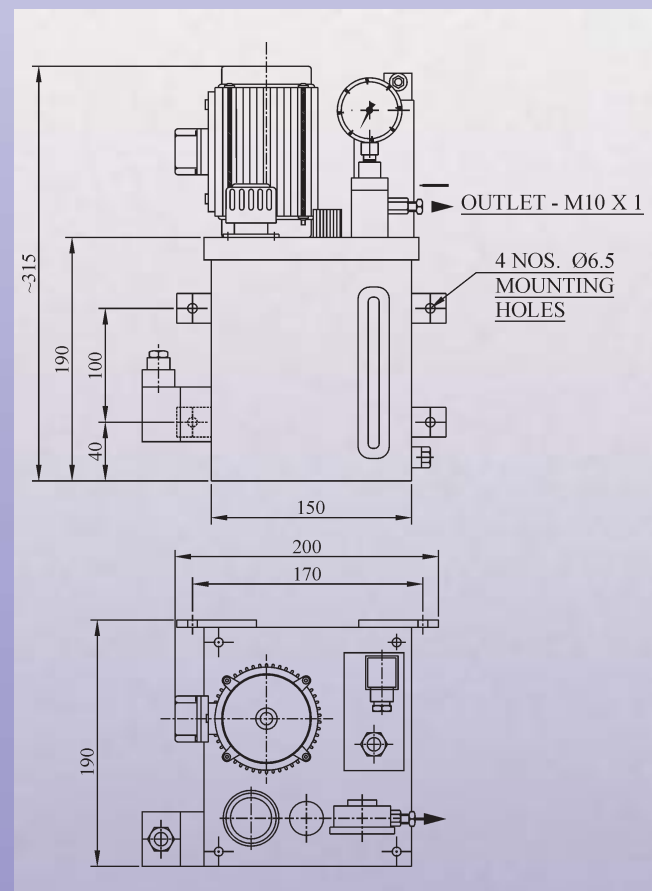

SINGLE SHOT OIL SYSTEM



CHAPTER-15

PUMP

Motorised Unit

MODEL ALU-CEN-03 CE

- This is a mini hydraulic power pack fitted with a motor and rotary positive displacement pump.
- The unit is designed for intermittent run only and is best suited for Single Shot Lubrication.
- Unit is fitted with a suitable pressure switch, float switch and oil window for checking oil level.
- During ON cycle, (5 sec. fixed), the electrically driven pump discharges the oil with high pressure, adjustable between 15-20 bars, with the help of an in-built relief valve, for safeguarding the system from over-loading.
- During OFF cycle (any time more than 2 minutes - adjustable) the pressure in the lubrication line is reduced to 1 kg/sq.cm.
- The system is also provided with a bleed valve near the outlet port to automatically bleed air if entrained in system.
- For vertical mounting of the unit, four holes are provided at the back of the system.
- There is an in-built check valve and pressure reducing system incorporated in the pump.
- Outlet port is suitable for 6mm OD tube.



Discharge of pump : 1 LPM.
Reservoir capacity : 3 ltrs. (in Mild Steel).
Motor (CE) : 0.09KW, 3 phase, 4 Pole, 415 V, 50 Hz.
Relief valve : Pre-set at 15-20 kg/sq.cm.
Pressure switch (CE) : 42 V (Max), 0.2 A (Max), Pre-set at 12 kg/cm², 1NO+1NC contact.
Float switch (CE) : 42 V (Max), 0.1 A (Max) (Vertical reed type) with 1NC contact (oil filled)
Electronic controller : Optional
Suitable oil viscosity : Between 32 to 680 cSt/40⁰C.
Best suited for medium size machines for export.

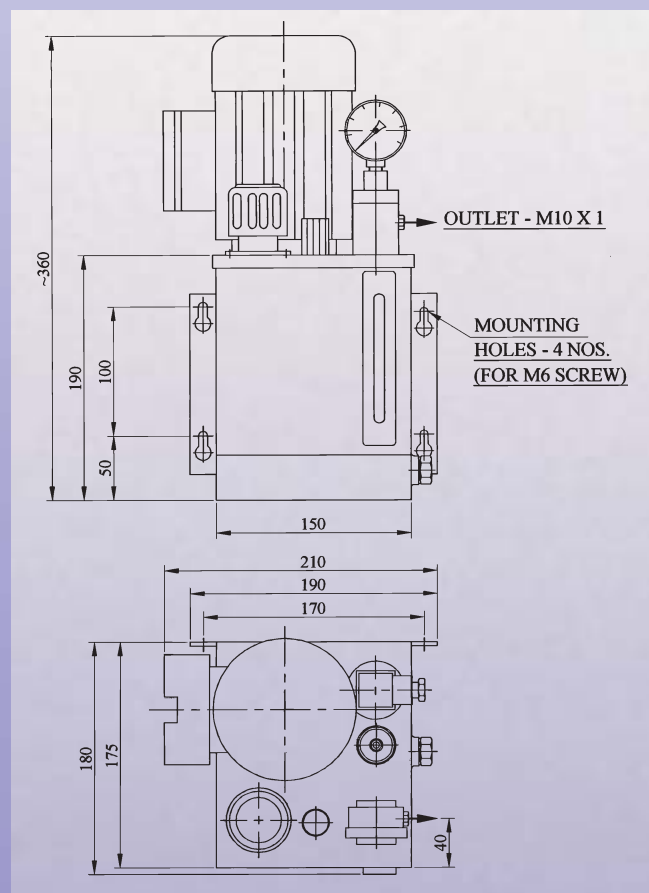

SINGLE SHOT OIL SYSTEM



CHAPTER-16

PUMP

Motorised Unit

MODEL ALU-05

- This is a mini hydraulic power pack fitted with a motor and rotary positive displacement pump.
- The unit is designed for intermittent run only and is best suited for Single Shot Lubrication.
- Unit is fitted with a suitable pressure switch, float switch and oil window for checking oil level.
- During ON cycle, the electrically driven pump discharges the oil with high pressure, adjustable between 18-20 bars, with the help of an in-built relief valve, for safeguarding the system from over-loading.
- During OFF cycle the pressure in the lubrication line is reduced to 1 kg/sq.cm.
- The system is also provided with a bleed valve near the outlet port to automatically bleed air if entrained in system.
- For vertical mounting of the unit, four holes are provided at the back of the system.
- There is an in-built check valve and pressure reducing system incorporated in the pump.
- Outlet port is suitable for 6mm OD tube.



Discharge of pump	: 1 LPM.
Reservoir capacity	: 5 ltrs. (in Mild Steel).
Motor	: 0.12KW, 1500 rpm, 3 phase, 415 V.
Relief valve	: Pre-set at 18-20 kg/sq.cm.
Pressure switch	: 220 V (Max), 1 A (Max), Pre-set at 15 kg/sq. cm., 1NO+1NC contact.
Float switch	: 220 V (Max), 0.2 A (Max) with 1NC Contact (Oil filled)
Electronic controller	: Optional
Suitable oil viscosity	: Between 32 to 680 cSt 40 ⁰ C.
Best suited for big size machines.	

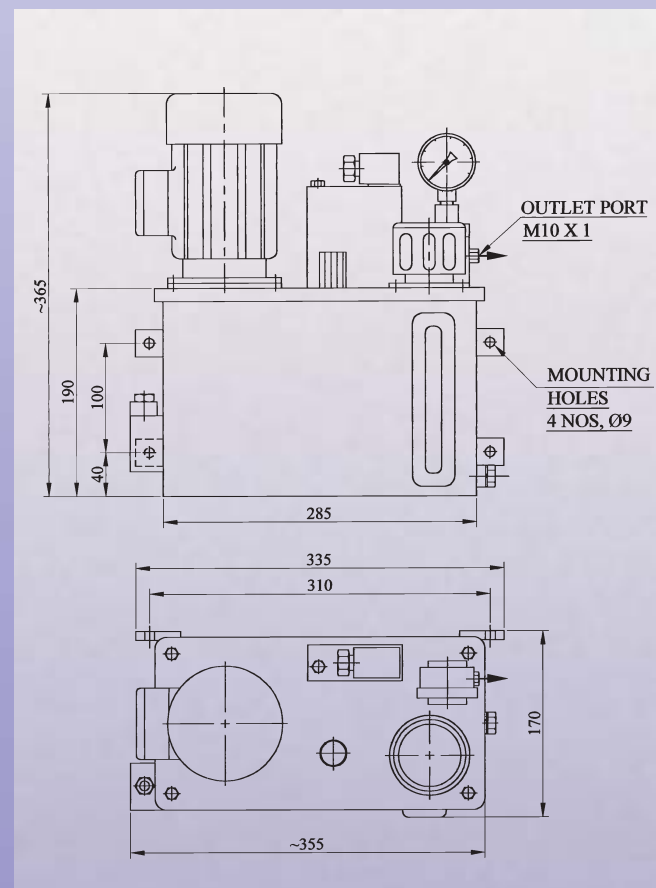

CHAPTER-17

PUMP

Motorised Unit

MODEL ALU-05 CE

- This is a mini hydraulic power pack fitted with a motor and rotary positive displacement pump.
- The unit is designed for intermittent run only and is best suited for Single Shot Lubrication.
- Unit is fitted with a suitable pressure switch, float switch and oil window for checking oil level.
- During ON cycle, the electrically driven pump discharges the oil with high pressure, adjustable between 18-20 bars, with the help of an in-built relief valve, for safeguarding the system from over-loading.
- During OFF cycle the pressure in the lubrication line is reduced to 1 kg/sq.cm.
- The system is also provided with a bleed valve near the outlet port to automatically bleed air if entrained in system.
- For vertical mounting of the unit, four holes are provided at the back of the system.
- There is an in-built check valve and pressure reducing system incorporated in the pump.
- Outlet port is suitable for 6mm OD tube.

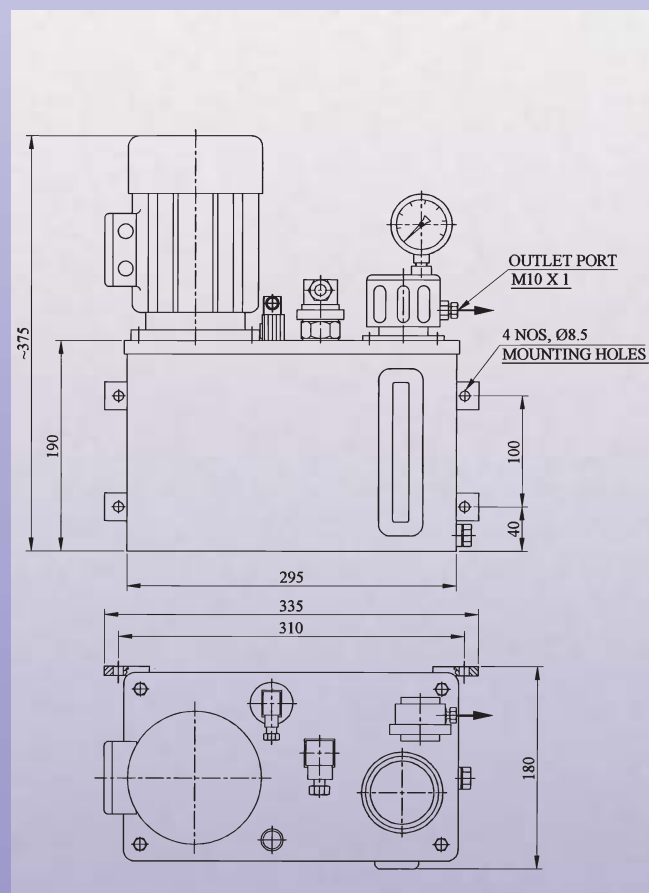

Discharge of pump	: 1 LPM.
Reservoir capacity	: 5 ltrs. (in Mild Steel).
Motor (CE)	: 0.12KW, 1500 rpm, 3 phase, 415 V.
Relief valve	: Pre-set at 18-20 kg/sq.cm.
Pressure switch (CE)	: 42 V (Max), 0.2 A (Max), Pre-set at 15 kg/sq. cm., 1NO+1NC contact.
Float switch (CE)	: 42 V (Max), 0.2 A (Max) with 1NC contact (Oil filled)
Electronic controller	: Optional
Suitable oil viscosity	: Between 32 to 680 cSt 40 ⁰ C.
Best suited for big size machines for export.	

SINGLE SHOT OIL SYSTEM



CHAPTER-18

PUMP

Motorised Unit

MODEL ALU-08 :

- This is a mini hydraulic power pack fitted with a motor and rotary positive displacement pump.
- The unit is designed for intermittent run only and is best suited for Single Shot Lubrication.
- Unit is fitted with a suitable pressure switch, float switch and oil window for checking oil level.
- During ON cycle, the electrically driven pump discharges the oil with high pressure, adjustable between 20–25 bars, with the help of an in-built relief valve, which is also safeguarding the system from over-loading.
- During OFF cycle the pressure in the lubrication line is reduced to 1 kg/sq.cm.
- The system is also provided with a bleed valve near the outlet port to automatically bleed air if entrained in system.
- For vertical mounting of the unit, four holes are provided at the back of the system.
- There is an in-built check valve and pressure reducing system incorporated in the pump.
- Outlet port is suitable for 6mm OD tube.



Discharge of pump : 1.5 LPM.
Reservoir capacity : 8 ltrs. (in Mild Steel).
Motor : 0.18KW, 1500 rpm, 3 phase, 415 V, fan cooled.
Relief valve : Pre-set at 20-25 kg/sq.cm.
Pressure switch : 220 V (Max), 1 A (Max)
Pre-set at 18 kg/sq. cm.,
1NO+1NC contact.
Float switch : 220 V (Max), 0.2 A (Max)
with 1NC contact (Oil filled)
Electronic controller : Optional
Suitable oil viscosity : Between 32 to 680 cSt 40⁰ C.
Best suited for big size machines.

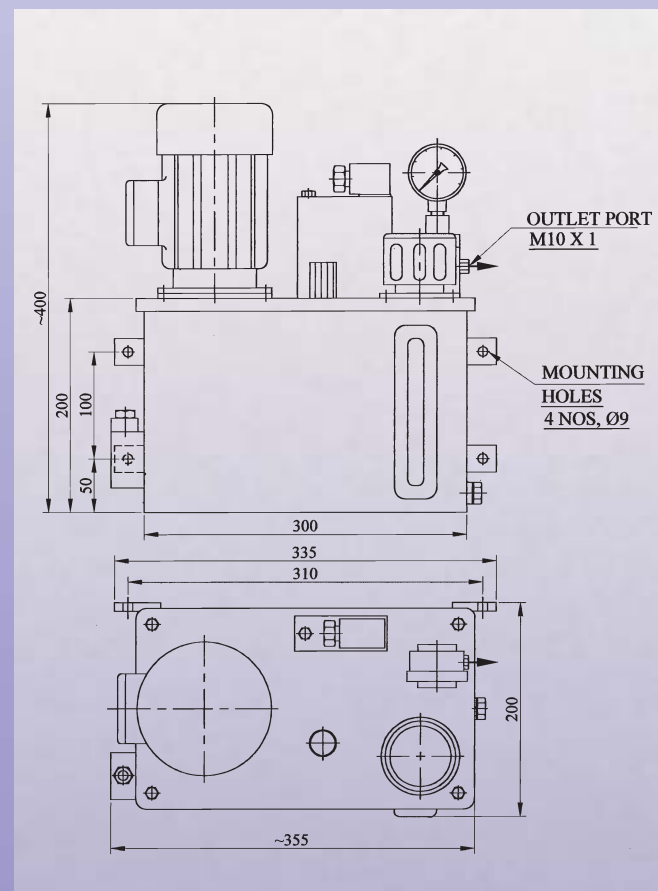

SINGLE SHOT OIL SYSTEM



CHAPTER-19

PUMP

Motorised Unit

MODEL ALU-08 CE

- This is a mini hydraulic power pack fitted with a motor and rotary positive displacement pump.
- The unit is designed for intermittent run only and is best suited for Single Shot Lubrication.
- Unit is fitted with a suitable pressure switch, float switch and oil window for checking oil level.
- During ON cycle, the electrically driven pump discharges the oil with high pressure, adjustable between 20-25 bars, with the help of an in-built relief valve, for safeguarding the system from over-loading.
- During OFF cycle the pressure in the lubrication line is reduced to 1 kg/sq.cm.
- The system is also provided with a bleed valve near the outlet port to automatically bleed air if entrained in system.
- For vertical mounting of the unit, four holes are provided at the back of the system.
- There is an in-built check valve and pressure reducing system incorporated in the pump.
- Outlet port is suitable for 6mm OD tube.

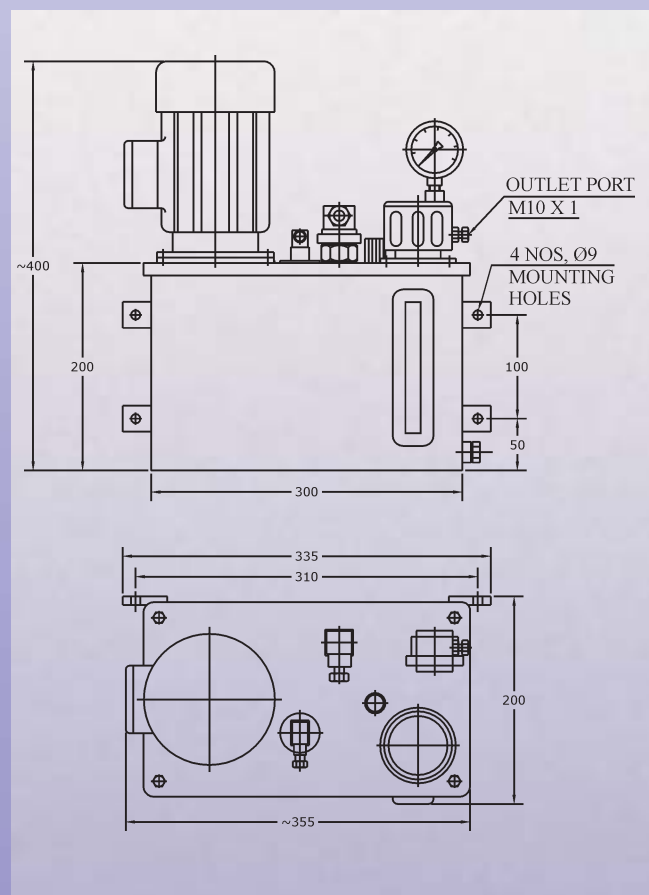

Discharge of pump : 1.5 LPM.
Reservoir capacity : 8 ltrs. (in Mild Steel).
Motor (CE) : 0.18KW, 1500 rpm,
3 phase, 415 V, fan cooled
Relief valve : Pre-set at 20-25 kg/sq.cm.
Pressure switch : 42 V (Max), 0.2 A (Max),
(CE) Pre-set at 18 kg/sq. cm.,
1NO contact
Float switch (CE) : 42 V (Max), 0.2 A (Max),
1NC contact (Oil filled)
Electronic controller : Optional
Suitable oil viscosity : Between 32 to 680 cSt/40⁰ C.
Best suited for big size machines for export.

SINGLE SHOT OIL SYSTEM



CHAPTER-20

PUMP

Pneumatically Operated

MODEL Pn-600-6

- It is Pneumatically operated pump.
- Reservoir is of Aluminium.
- Whenever compressed air is given to the pump at the input port, piston moves up and discharges oil from the outlet.
- During OFF time of the compressed air, pump gets recharged, sucking oil from the reservoir.
- Mounting of the pump is through 4 holes in vertical position.
- There is a built in relief valve in the pump to safeguard it from overloading.
- There is a special pressure reducing valve provided with the pump to bring down the pressure towards "0" during OFF time.



Input air pressure : 5-6 kg/cm²
Output oil pressure : 15 kg/cm²
Discharge of oil : 6 cc per stroke
Reservoir capacity : 600 cc
Material of reservoir : Aluminium casting
Suitable oil viscosity : Between 32 to 680 cSt/40° C
Best suited for medium size machines where pneumatic line is available.

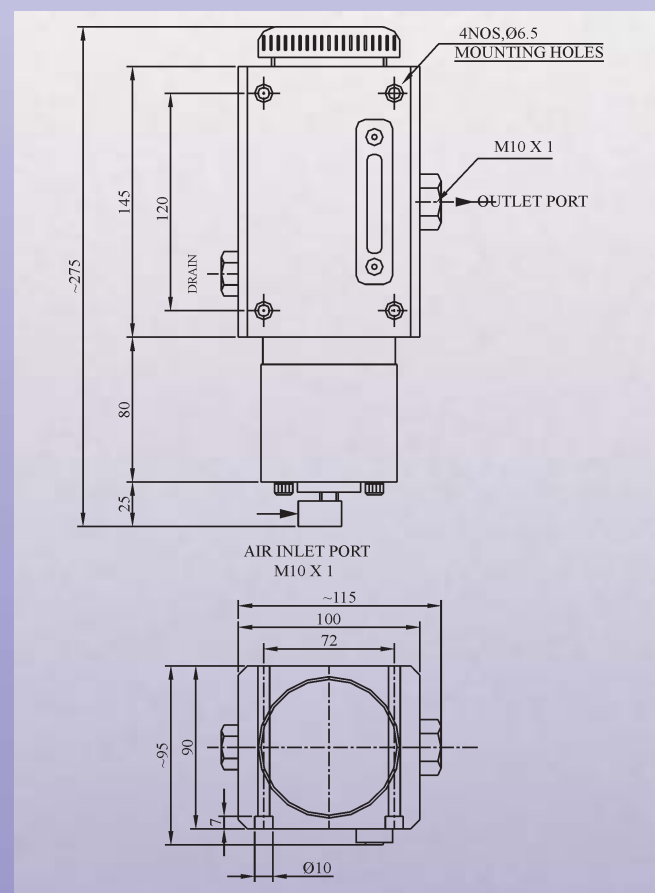

SINGLE SHOT OIL SYSTEM



CHAPTER-21

PUMP

Pneumatically Operated

MODEL Pn-1700-10

- It is a Pneumatically operated pump.
- Reservoir is of Aluminium.
- Whenever compressed air is given to the pump at the input port, piston moves up and discharges oil from the outlet.
- During OFF time of the compressed air, pump gets recharged, sucking oil from the reservoir.
- Mounting of the pump is through 4 holes in vertical position.
- There is a built in relief valve in the pump to safeguard it from overloading.
- There is a special pressure reducing valve provided with the pump to bring down the pressure towards "0" during OFF time.

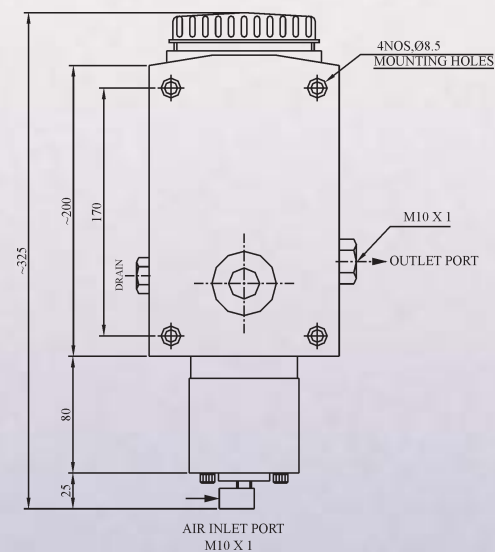

Input air pressure : 5-6 kg/cm²
Output oil pressure : 18 kg/cm²
Discharge of oil : 10 cc per stroke
Reservoir capacity : 1.7 litres
Material of reservoir : Aluminium casting
Suitable oil viscosity : Between 32 to 680 cSt/40° C
Best suited for bigger size machines where pneumatic line is available.

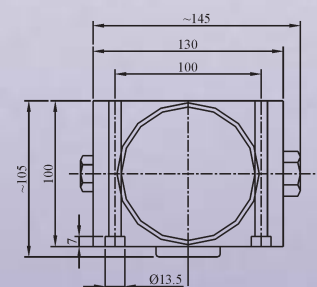

SINGLE SHOT OIL SYSTEM



CHAPTER-22

PUMP

Pneumatically Operated

MODEL Pn-3000-10

- It is a Pneumatically operated pump.
- Reservoir is Metallic.
- Whenever compressed air is given to the pump at the input port, piston moves up and discharges oil from the outlet.
- During OFF time of the compressed air, pump gets recharged, sucking oil from the reservoir.
- Mounting of the pump is through 4 holes in vertical position.
- There is a built in relief valve in the pump to safeguard it from overloading.
- There is a special pressure reducing valve provided with the pump to bring down the pressure towards "0" during OFF time.

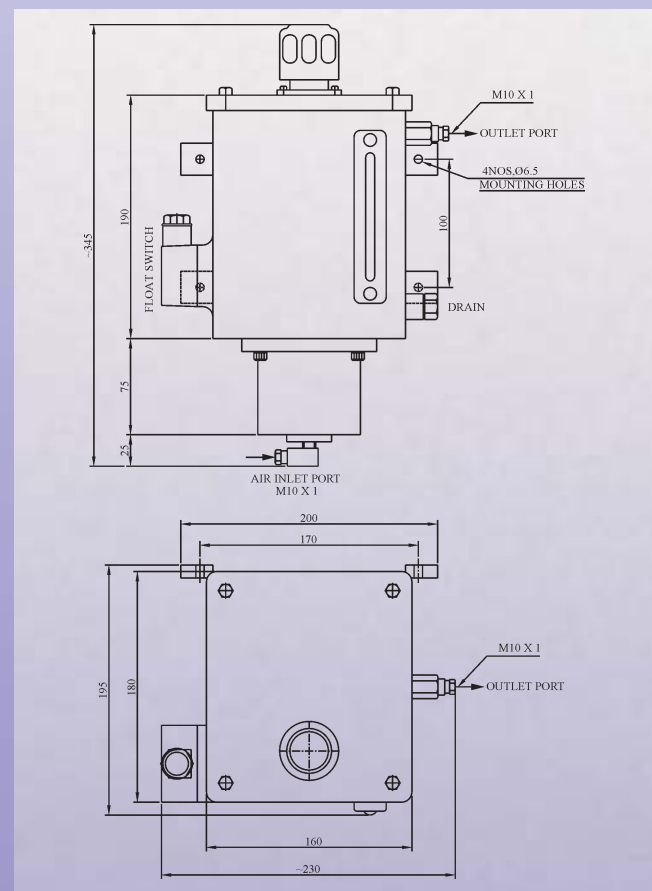

Input air pressure : 5-6 kg/cm²
Output oil pressure : 18 kg/cm²
Discharge of oil : 10 cc per stroke
Reservoir capacity : 3 litres
Material of reservoir : Mild Steel
Suitable oil viscosity : Between 32 to 680 cSt/40° C
Best suited for bigger size machines where pneumatic line is available.

CHAPTER-23

METERING CARTRIDGES

- The element is a valve which ejects out metered amount of oil to lubrication point instantaneously.
- It is a sort of mini cylinder with a special check valve where stroke of piston determines the dosage of oil.
- The complete design of metering cartridge does not allow it to leak at low as well as at high pressure of oil.
- Operating oil pressure for metering cartridges is 10-30 kg/cm².
- Outlet ports of metering cartridges are suitable for 4mm OD tube.
- For metering cartridges, next cycle of ejection of oil is only possible when pressure of oil in lubrication line comes down towards zero.



The various models are :

D1 * Dosage :

With dosage 0.01/0.03/0.05/0.10/0.16 cc per cycle with $\pm 15\%$ accuracy of dosage.

D X 1 * Dosage :

Above items with honed bore, silicon rubber with $\pm 10\%$ accuracy of dosage.

D2 * Dosage :

With dosage 0.25/0.40 cc per cycle with $\pm 10\%$ accuracy of dosage.

D X 2 * Dosage :

Above items with honed bore, silicon rubber with $\pm 10\%$ accuracy of dosage.

D3 * Dosage :

With dosage 1.0/1.60 cc per cycle with $\pm 15\%$ accuracy of dosage.

D X 3 * Dosage :

Above items with honed bore, silicon rubber with $\pm 10\%$ accuracy of dosage.

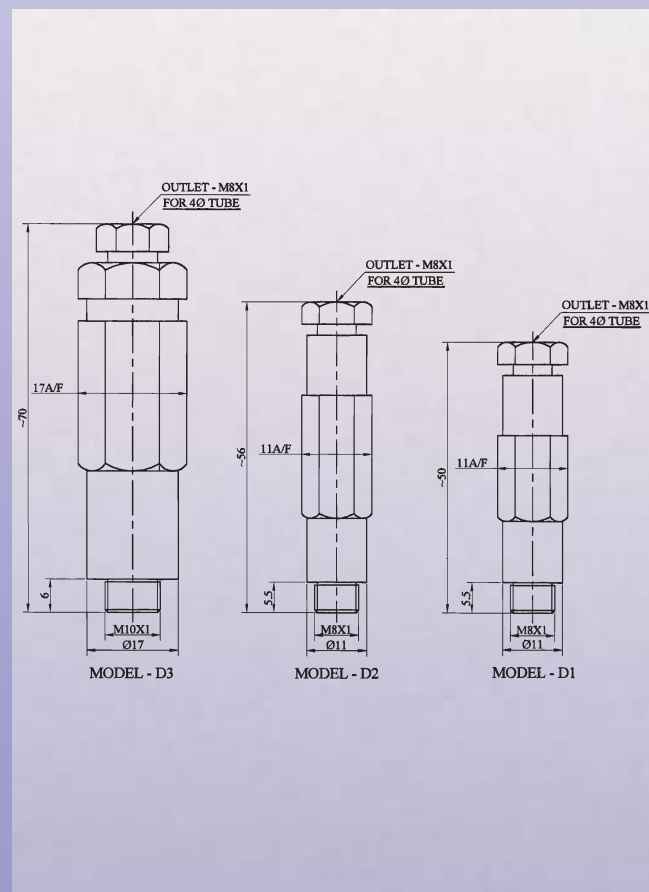

* indicates nomenclature of metering cartridge w.r.t. dosage of oil e.g. D2-0.40.

CHAPTER-24

MANIFOLDS

- Manifolds are nothing but steel blocks for mounting metering cartridges. These have two ports and few side outlets. On side outlets, metering cartridges are screwed directly while in line ports are meant for joining next manifold in line with 6 mm OD tube. For fixing manifold on machine wall, there are mounting holes suitable for M5 screws.
- For D1 and D2 models of metering cartridges, there are manifolds of 4 sizes namely, 1 way (Model M1), 2 way (Model M2), 3 way (Model M3) and 5 way (Model M5).

The nomenclature states the number of cartridges, a manifold can maximum accommodate. The manifolds have M8 x 1 tapping for fitment of metering cartridges. The unused side outlets can be blocked with M8 x 1 plugs.

- For D3 model of metering cartridges, there are manifolds of 2 sizes namely 1 way (Model M1A), 3 way (Model M3A).

The nomenclature states the number of cartridges, a manifold can maximum accommodate. The manifolds have M10x1 tapping for fitment of metering cartridges. The unused side outlet can be blocked with M10x1 plugs.

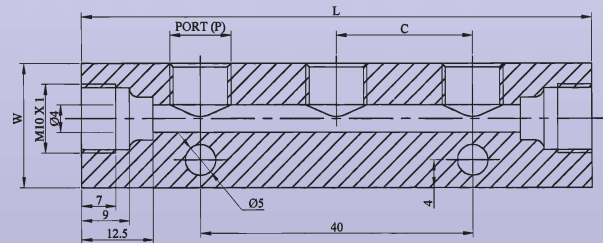
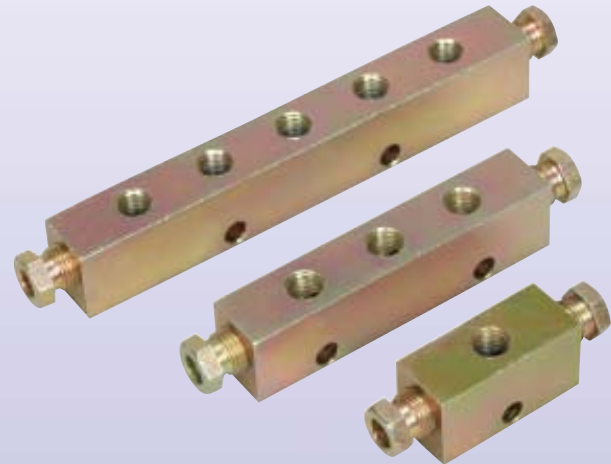

Model	L	No of mounting holes	W	Thickness	Port size-P	Center distance C
M1-1 way	35	One	18	15	M8x1	N.A.
M2-2 way	55	One	18	15	M8x1	20
M3-3 way	75	Two	18	15	M8x1	20
M5-5 way	115	Two	18	15	M8x1	20
M1A-1 way	40	One	22	22	M10x1	N.A.
M3A-3 way	90	Two	22	22	M10x1	25

CHAPTER-25

FITTING AND TUBING

- Tubing and fittings are basic accessories for the lubrication system.
- From the pump to the manifold and from the manifold to the lubrication point with metering cartridges in between, tubings are required. These can be steel tube, copper tube, nylon tube or hoses.
- For ejecting oil into the lubrication points, fittings are available of various thread sizes. These fittings have provision for tightening 4 Ø tube and thus are provided with locking screw and cone (ferrule).

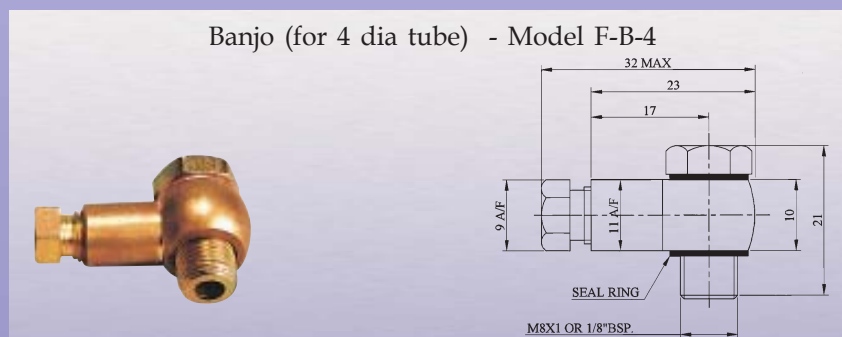
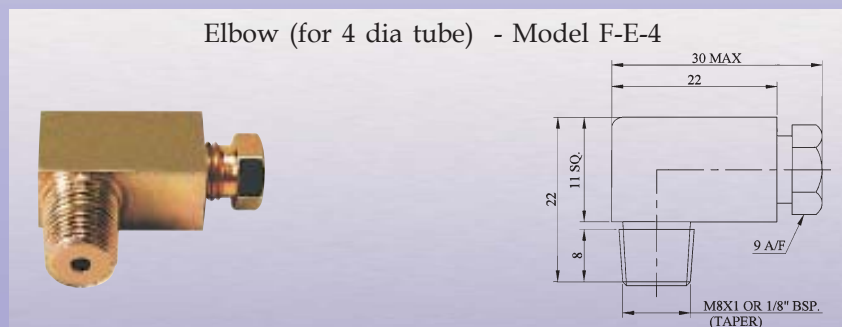
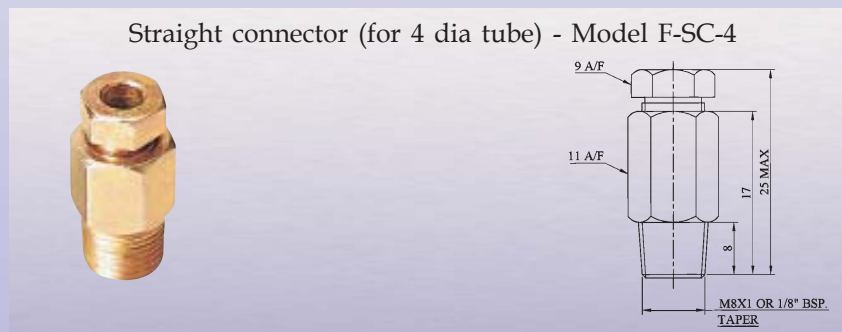

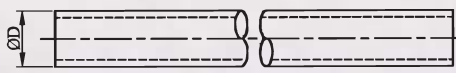

SINGLE SHOT OIL SYSTEM



STEEL TUBE

Model	ØD	Wall Thickness
ST-6	6	0.7
ST-4	4	0.7

NYLON TUBE

Model	ØD	Wall Thickness
NT-6	6	1
NT-4	4	1

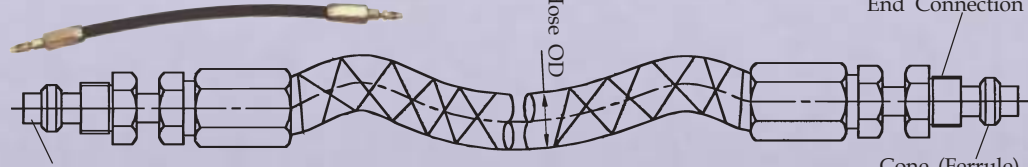
HOSE TUBE

Model	Tube OD	Hose OD	End Connection
RH-6	6	8	M10x1
RH-4	4	8	M8x1

Total hose tube length to be specified.

CHAPTER-26

ELECTRONIC CONTROLLER

- Electronic Controller are high performance solid state instruments, intended for automatic control and monitoring of CENLUB centralised lubrication system.
- It provides precision control of lubrication cycle.
- It also has the facility of monitoring oil pressure and low oil level in the reservoir.
- Visual indications are given on the front panel to give "lub fault" or "fill oil" display.
- A fault relay enables the user to activate any corrective or display device in case of fault.



Model - ECC-1002X - Digi

- ON time - 5 sec. (after pressure switch signal).
- OFF time - 2, 4, 8, 15, 60, 120, 240 min {digital} with lubrication fault & low level signal.
- Wall mounting type.

Model - ECC-1002XP - Digi

- ON time - 5 sec. (after pressure switch signal).
- OFF time - 2, 4, 8, 15, 30, 60, 120, 240 min {digital} with lubrication fault & low level signal.
- Panel mounting type.

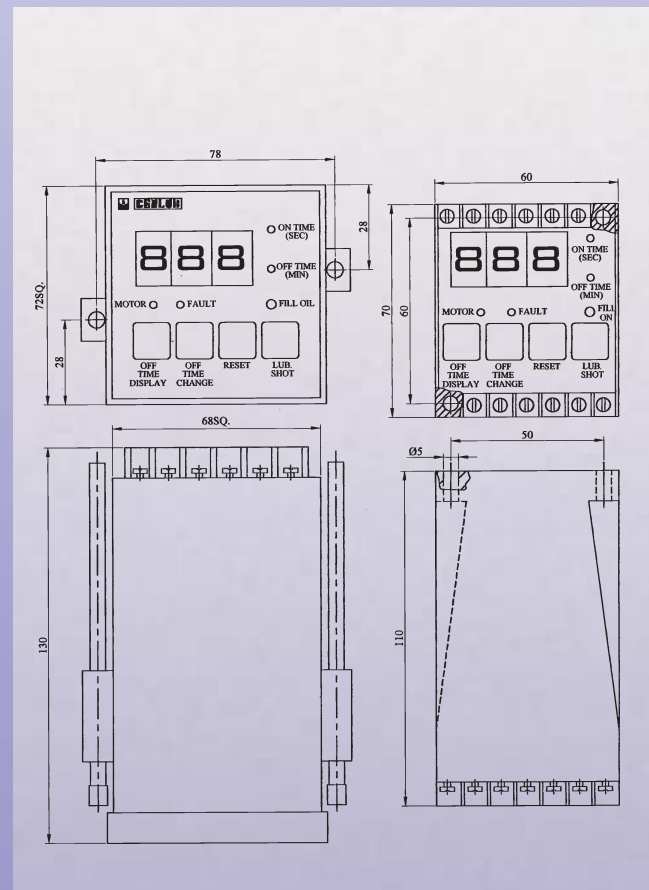

Operating voltage : 110 or 240 V AC
(user selectable) / 50 Hz.

Operating voltage : 85 to 110 % of nominal.
range

Operating mode : Time controlled.

CHAPTER-27

ELECTRONIC TIMER

- Electronic Timers are high performance solid state instruments, intended for automatic control and monitoring of CENLUB centralised lubrication system.
- It provides precision control of lubrication cycle.
- It does not have the facility of monitoring oil pressure and low oil level in the reservoir.

The various models are :

ETF-5-240

- ON time - 5 sec (fixed)
- OFF time - 5/30/60/180/240 min. (settable)
- With manual lub shot facility.

ETF-2-30/2-60

- ON time - 2/5/10/15/20/25/30 sec. (settable)
- OFF time - 2/10/20/30/40/50/60 min. (settable).

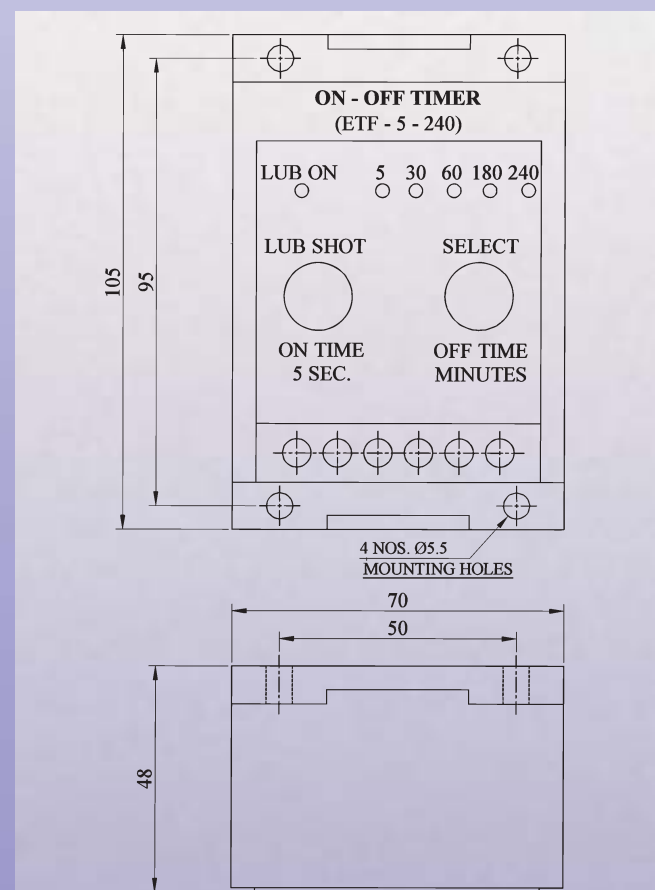

Operating voltage : 230 V AC
(user selectable) / 50 Hz.

Operating voltage : 85 to 110 % of nominal.
range

Operating mode : Time controlled.

PLANNING/INSTALLATION OF SYSTEM

Single shot centralised lubrication system has been widely accepted as a method to deliver metered dosages to number of lubrication points on a machine simultaneously from a single source.

While planning this system, following procedure should be adopted.

1. Ascertain lubrication points and find out the areas to be lubricated at corresponding lubrication points of machine.
2. Estimate dosages of lubricant required on each point.
3. Select metering cartridges according to lubricant dosage.
4. Sum up the dosage of oil for all the lubrication points.
5. Depending upon machine requirement, finalise the type of pump, *i.e.* hand operated/pneumatically operated/motorised.
6. In case pump finalised is hand/pneumatically operated; select model whose discharge per stroke is more than 1.5 times total oil requirement per lubrication cycle as calculated under point No. 4. This is to overcome tube expansion and other losses and to guarantee pressure in lubrication line at desired value.

In case of motorised lubrication unit, select the model depending upon size of machine and rate of consumption of oil. Of course bigger model suits for a machine of bigger size and it gives as added advantage of refilling oil tank (reservoir) with more time gap. In case number of lubrication points are not many and machine is small, smaller model aesthetically will be a better selection.
7. As regards frequency of lubrication, for general application, an hourly lubrication is optimum for a machine running with its normal load condition. For lightly - loaded machine, frequency can be relaxed to 2-4 hours. If machine is heavily loaded, frequency can be adjusted to few minutes (10-15 min.).
8. As regards layout of tubings and fittings it is so arranged that air which has entered the system may escape through lubrication points. For this purpose, following points are to be observed :
 - (a) Preferably pump or unit be installed at a place on the machine where oil level and pressure can be checked and refilling of oil can be done conveniently.
 - (b) Main line from the pump should rise upward.
 - (c) If main line is to be taken downward at any place, bifurcate the line such that one line goes upward also at the junction.
 - (d) Last metering cartridge/cartridges in every branch of lub. line must point upward.
 - (e) Divide the main line into 2 or 3 branches near the pump, instead of routing one single line around the machine. This will minimise the tube length and give better appearance and ease of maintenance of system.
 - (f) Selection of manifolds should be such that a manifold caters to all the lubrication points existing in the same vicinity.
 - (g) The secondary line joining metering cartridges to lubrication points should be of minimum length. This is to avoid unnecessary time for filling secondary tube by lubrication impulses while commissioning lubrication system.
 - (h) Connect outlet of each metering cartridge to one lubrication point only.
 - (i) Use flexible tube (nylon or rubberised hose) for moving parts of machine.
 - (j) In case of lubrication point situated in the hot zone of the machine (or the zone where hot metal chips are likely to fall such as on the fixture), do not use nylon tube.
9. While commissioning centralised lubrication system on a machine, loose the last plug/plugs screwed on the manifolds in each branch of main line. Give few lubrication impulses so that main line gets filled with the oil up to the end and oil starts leaking from the loosened plugs. Tight the plugs. Now give few lubrication impulses, until oil from all the metering cartridges reaches up to lubrication points on the machine. Once this is achieved, the system becomes ready for use.
10. In case of automatic lubrication system, control parts for lubrication frequency and fault detection can be set according to the machine requirement.

CENLUB INDUSTRIES LIMITED

35, DLF Industrial Estate-I, Faridabad-121 003, India
Tel. : +91-129-4113701, 4113702, 4113703, 4113704, 2275483
Fax : +91-129-2260524, 2275484

E-mail : cenlub@cenlub.in

CENLUB INDUSTRIES LIMITED

45-B, Peenya Indl. Area, Phase-II, Bangalore-560058, India
Tel. : +91-80-65584624, 23723680
Fax : +91-80-28374704

Website : <http://www.cenlub.in>